

INSTRUCTION MANUAL

AZ TRACKING TELESCOPES

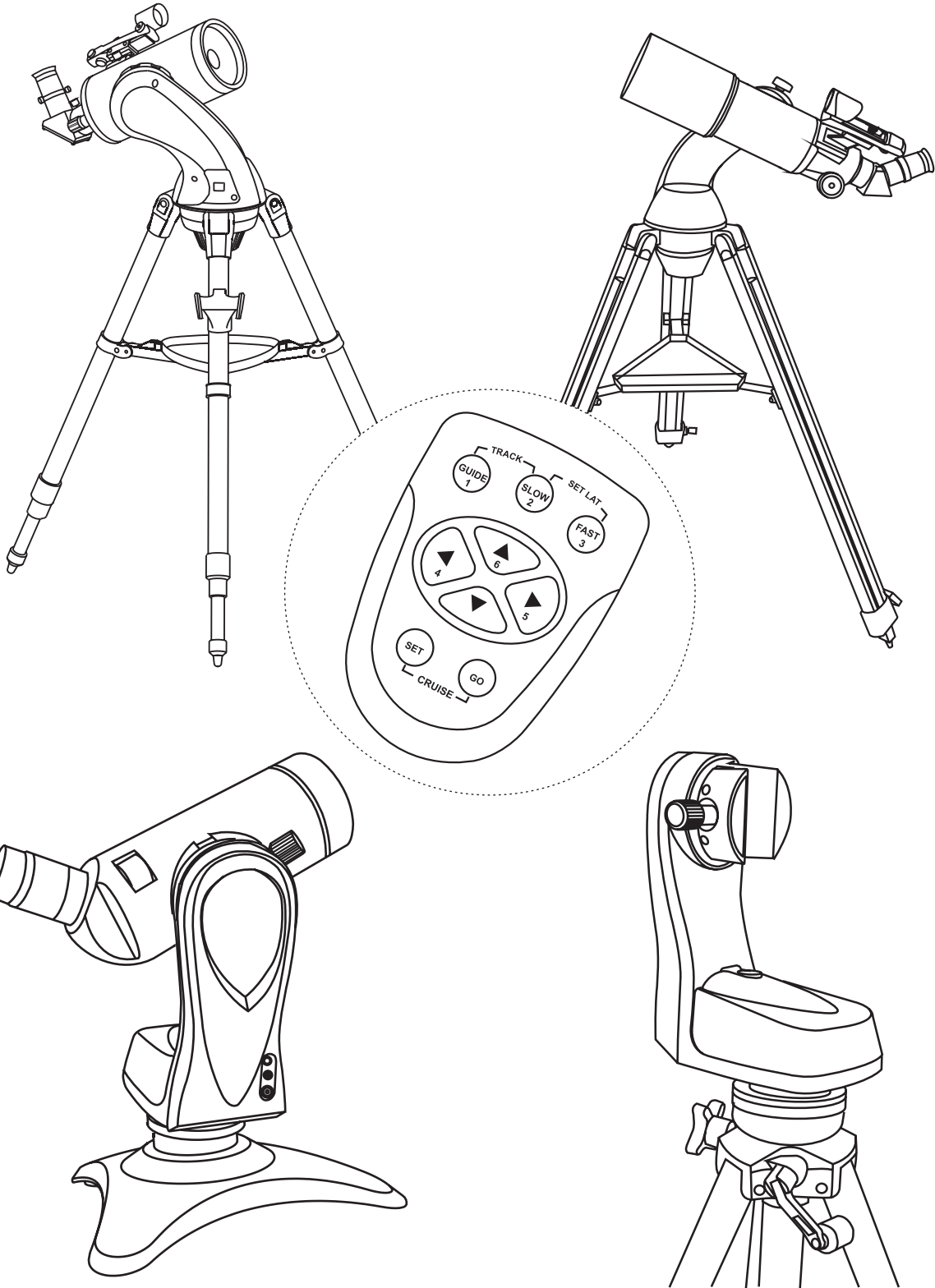

TABLE OF CONTENTS

TELESCOPE ASSEMBLY - AUTOTRACKING MOUNTS -----	3
TELESCOPE ASSEMBLY - MULTIFUNCTION MOUNTS -----	4
USING THE RED DOT FINDER -----	5
FOCUSING -----	5
CALCULATING THE MAGNIFICATION (POWER) -----	5
FOR ASTRONOMICAL USE -----	6
POWERING THE TELESCOPE -----	6
SETTING UP THE TELESCOPE -----	6
SETTING THE LOCAL LATITUDE FOR ACCURATE TRACKING -----	7
HAND CONTROL OPERATION -----	7
FOR TERRESTRIAL USE -----	8
SETTING UP THE TELESCOPE -----	8
HAND CONTROL OPERATION -----	8

BEFORE YOU BEGIN

This instruction manual is applicable to all the models listed on the cover. Follow the instructions for your specific model in the manual. Read the entire instructions carefully before beginning. Your telescope should be assembled during daylight hours. Choose a large, open area to work to allow room for all parts to be unpacked.



- NEVER LOOK AT THE SUN WITH THE NAKED EYE OR WITH A TELESCOPE (UNLESS YOU HAVE THE PROPER SOLAR FILTER). PERMANENT AND IRREVERSIBLE EYE DAMAGE MAY RESULT.
- IF OBSERVING THE SUN (WHILE USING A PROPER SOLAR FILTER) WITH YOUR TELESCOPE, MAKE SURE THAT THE FINDERSCOPE HAS A DUST CAP OVER THE OBJECTIVE END OR REMOVE THE FINDERSCOPE.
- NEVER USE YOUR TELESCOPE TO PROJECT AN IMAGE OF THE SUN ONTO ANY SURFACE. INTERNAL HEAT BUILD-UP CAN DAMAGE THE TELESCOPE AND ANY ACCESSORIES ATTACHED TO IT.
- NEVER USE AN EYEPIECE SOLAR FILTER OR A HERSHEY WEDGE. INTERNAL HEAT BUILD-UP INSIDE THE TELESCOPE CAN CAUSE THESE DEVICES TO CRACK OR BREAK, ALLOWING UNFILTERED SUNLIGHT TO PASS THROUGH TO THE EYE.
- DO NOT LEAVE THE TELESCOPE UNSUPERVISED, EITHER WHEN CHILDREN ARE PRESENT OR ADULTS WHO MAY NOT BE FAMILIAR WITH THE CORRECT OPERATING PROCEDURES OF YOUR TELESCOPE.

TELESCOPE ASSEMBLY - AUTOTRACKING MOUNTS

TRIPOD SET UP

Fig.1

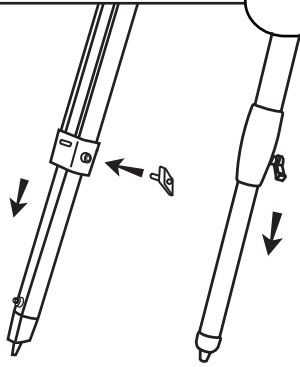

ADJUSTING TRIPOD LEGS (Fig.1)

- 1) Slowly loosen the height adjustment clamp and gently pull out the lower section of each tripod leg. Tighten the clamps to hold the legs in place.
- 2) Spread the tripod legs apart to stand the tripod upright.
- 3) Adjust the height of each tripod leg until the tripod head is properly leveled.
Note that the tripod legs may not be at same length when the mount is level.

Fig.2

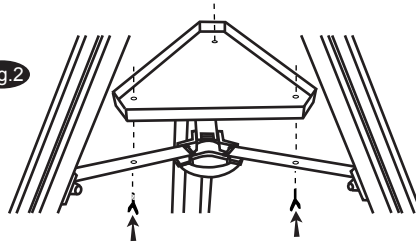

ATTACHING THE TRIANGLE ACCESSORY TRAY (Fig. 2)

- 1) Place the accessory tray on top of the bracket, and secure with the locking knob from underneath.

Fig.3

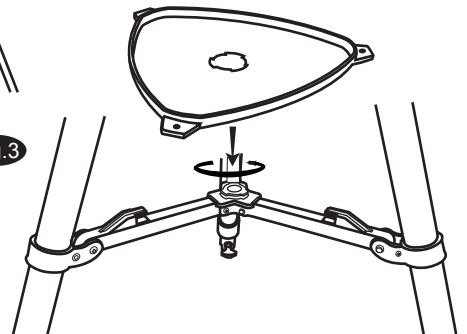

ATTACHING THE QUICK-RELEASE ACCESSORY TRAY (Fig. 3)

- 1) Hold the accessory tray directly above the bracket. Rotate the tray until the shape of the hole matches the locking mechanism in the center of the bracket. Place the tray on top of the bracket and rotate to lock the tray in place.

TELESCOPE ASSEMBLY

Fig.4

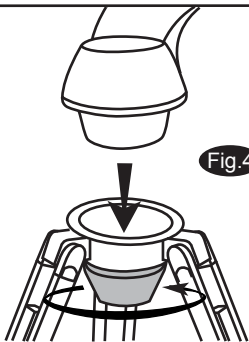

ATTACHING THE MOUNT TO THE TRIPOD (Fig.4)

- 1) Place the single arm mount into the tripod head.
- 2) Push the large cup underneath the tripod head upward and turn counter-clock wise to secure the mount to the tripod.

ATTACHING THE TELESCOPE TUBE TO THE MOUNT (Fig.5)

The dovetail type

- 1) Loosen the black screw on the top of the mount until it is not protruding from the dovetail acceptor.
- 2) Find the approximate balance point on the telescope tube.
- 3) Slide in the telescope tube until the balance point of the telescope falls in the center of the mount head. Tighten the screw until the dovetail bar on the telescope tube is securely fastened on the mount.

Fig.5

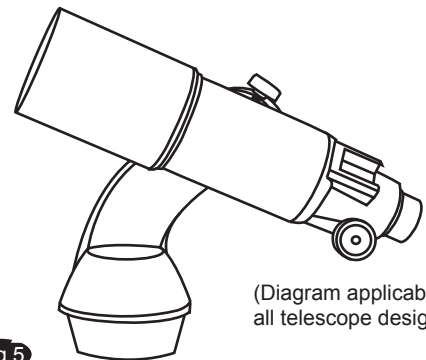

(Diagram applicable to all telescope designs.)

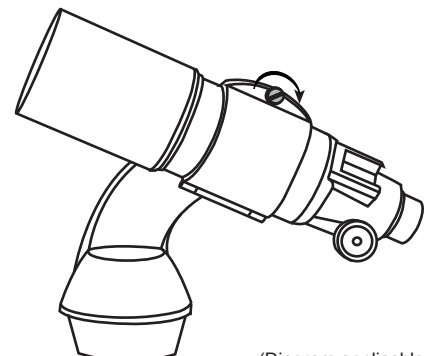

(Diagram applicable to all telescope designs.)

The clamp type

- 1) Remove the black screw on the top of the cradle ring and place it at a safe place for later use.
- 2) Carefully open the cradle ring just enough so the telescope tube can be slid in.
- 3) Slide in the telescope tube. Close the cradle ring and insert the black screw from the opposite side of the arm as shown in Fig.4. Tighten the screw until the telescope tube is securely fastened inside the cradle ring.

TELESCOPE ASSEMBLY - MULTIFUNCTION MOUNTS

TRIPOD & MOUNT SET UP

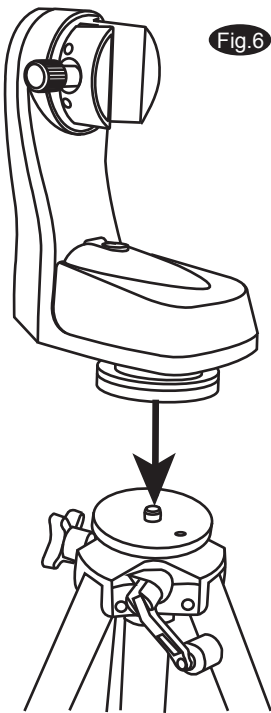

Fig.6

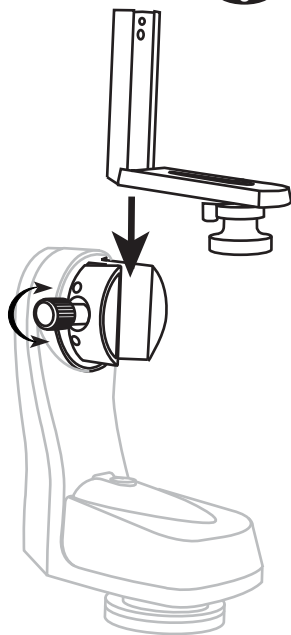

Fig.7

TRIPOD SET UP

1. Remove the tripod from the box and spread the legs apart until fully extended.
2. Adjust the desired height of the tripod before attaching the fork arm and your optical tube. Minor adjustments can be made later. Loosen the locking mechanisms on each leg and slide the legs to the desired height and then retighten them.

MOUNT SET UP

1. Next you will attach your Multi-function mount to the tripod. Locate the 3/8" threaded bolt in the top of the tripod platform. Then, find the mating 3/8" threaded hole underneath the Fork Arm Base. Thread the 3/8" bolt of the tripod platform into the 3/8" threaded hole in the fork arm base until it is good and tight (Fig.6).
2. Locate the 1/4x20 Mounting Platform. Slide it down the slot on the Fork Arm as indicated in Fig.7. Secure by tightening the thumb screws.

TELESCOPE ASSEMBLY

ATTACHING THE TELESCOPE TUBE TO THE MOUNT

1. If you are using the telescope for tracking astronomical objects, attach the optical tube to the Mounting Platform so that the Fork Arm is located on the right hand side (Fig.8). If the telescope is installed incorrectly you will not be able to use the latitude scale on the top of the Fork Arm. Thread the 1/4x20 Mounting Screw into the 1/4x20 tripod adapter of the optical tube and make sure it is tight. Do not overtighten the screw.

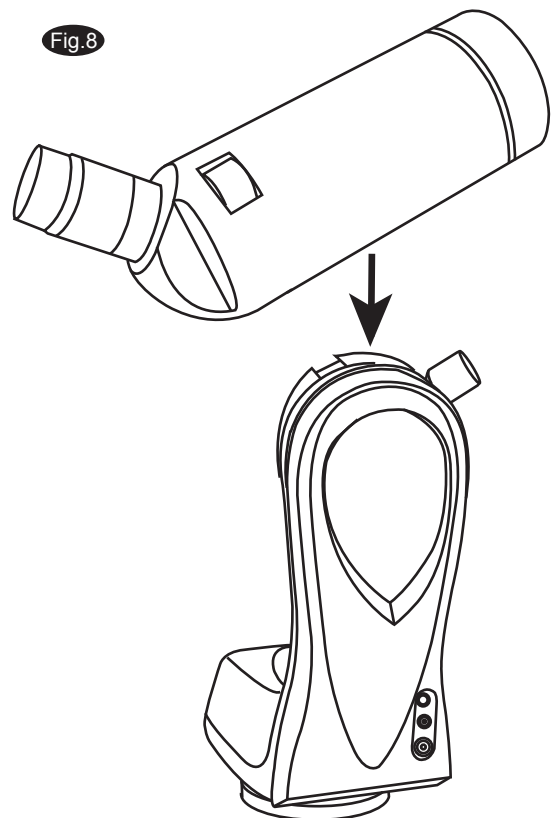

Fig.8



Telescopes with a dovetail bar attached can be installed directly onto the Multi-function mount without using the Mounting Platform.

ATTACHING A CAMERA TO THE MOUNT

1. For general terrestrial use, the camera can be secured on the Mounting Platform any way you wish. Thread the 1/4x20 Mounting Screw into the camera and make sure it is tight. Do not overtighten the screw.



Do NOT overtighten the 1/4x20 Mounting Screw or it may cause damage to the screw.



You must be careful not to use an optical tube that is too heavy or too big as the motor assembly will not be able to operate properly and you may damage the mount.

Using the Red Dot Finder

The Red Dot Finder is a zero magnification pointing tool that uses a coated glass window to superimpose the image of a small red dot onto the night sky. The Red Dot Finder is equipped with a variable brightness control, azimuth adjustment control, and altitude adjustment control (Fig.a). The Red Dot Finder is powered by a 3-volt lithium battery located underneath at the front. To use the Finder, simply look through the sight tube and move your telescope until the red dot merges with the object. Make sure to keep both eyes open when sighting.

Aligning the Red Dot Finder

Like all finderscopes, the Red Dot Finder must be properly aligned with the main telescope before use. This is a simple process using the azimuth and altitude control knobs.

1. Open the battery cover by pulling it down (you can gently pry at the 2 small slots) and remove the plastic shipping cover over the battery (Fig.b).
2. Turn on the Red Dot Finder by rotating the variable brightness control clockwise until you hear a "click". Continue rotating the control knob to increase the brightness level. Insert a low power eyepiece into the telescope's focuser.
3. Locate a bright object and position the telescope so that the object is in the centre of the field of view. With both eyes open, look through the sight tube at the object.
4. If the red dot overlaps the object, your Red Dot Finder is perfectly aligned. If not, turn its azimuth and altitude adjustment controls until the red dot is merged with the object.

Focusing

Slowly turn the focus knobs (Fig.c), one way or the other, until the image in the eyepiece is sharp. The image usually has to be finely refocused over time, due to small variations caused by temperature changes, flexures, etc. This often happens with short focal ratio telescopes, particularly when they haven't yet reached outside temperature. Refocusing is almost always necessary when you change an eyepiece or add or remove a Barlow lens.

Calculating the magnification (power)

The magnification produced by a telescope is determined by the focal length of the eyepiece that is used with it. To determine a magnification for your telescope, divide its focal length by the focal length of the eyepieces you are going to use. For example, a 10mm focal length eyepiece will give 80X magnification with an 800mm focal length telescope.

$$\text{magnification} = \frac{\text{Focal length of the telescope}}{\text{Focal length of the eyepiece}} = \frac{800\text{mm}}{10\text{mm}} = 80\text{X}$$

When you are looking at astronomical objects, you are looking through a column of air that reaches to the edge of space and that column seldom stays still. Similarly, when viewing over land you are often looking through heat waves radiating from the ground, house, buildings, etc. Your telescope may be able to give very high magnification but what you end up magnifying is all the turbulence between the telescope and the subject. A good rule of thumb is that the usable magnification of a telescope is about 2X per mm of aperture under good conditions.

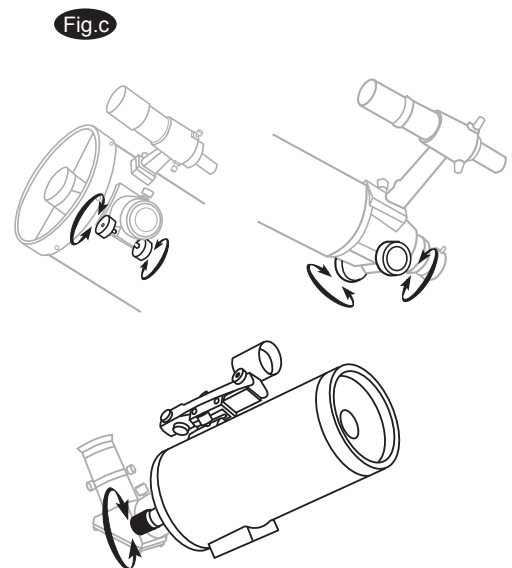
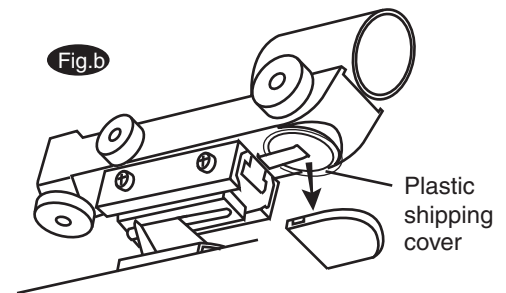
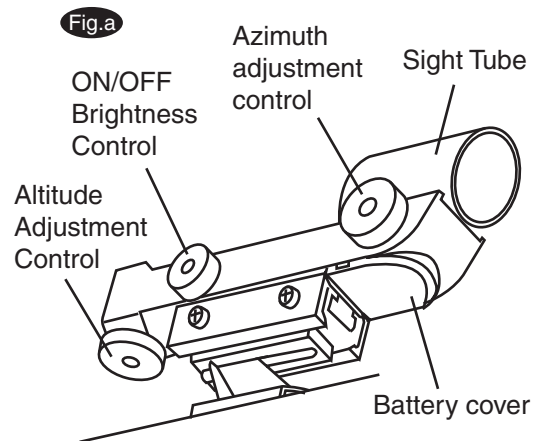

FOR ASTRONOMICAL USE

Powering the telescope

AUTOTRACKING TELESCOPES

The Auto-tracking Mount power requirement is 12-Volts DC Nominal. The maximum voltage should not exceed 16-volts and the minimum is 8-volts. The provided battery pack can hold eight (8) AA alkaline batteries. It can be placed in the tray on the tripod.

MULTIFUNCTION TELESCOPES

The Multi-Function Mount power requirement is 12-Volts DC Nominal. The maximum voltage should not exceed 16-volts and the minimum is 8-volts. The battery compartment holds eight (8) AA alkaline batteries (user supplied). Open the battery compartment by pressing down on the lever located in the front of the fork arm base (Fig.d). Remove the battery holders inside to install or replace batteries.

Setting up the telescope

AUTOTRACKING TELESCOPES

Plug the cable (connector) from the Hand Control into the telephone type jack at the side of the arm (Fig.e).

1. Plug the power cord into the outlet on the the side of the mount to turn on the power (Fig.e).
2. You will find a latitude scale near the top of the fork arm. Using the directional keys, adjust the telescope tube until the latitude scale reads 0. (Fig.f).
3. Next, the telescope must be pointing North from the location you are using (Fig.g).
4. After the above is accomplished, the telescope is now properly setup in the "Home" position.
5. Turn off the power and turn it back on again.

MULTIFUNCTION TELESCOPES

Plug the cable (connector) from the Hand Control into the telephone type jack marked HC at the side of the arm.

1. You will find a latitude scale with two index pointers near the top of the fork arm. If you are using a camera or a telescope mounted on the Mounting Platform, use the pointer on top as reference. If your telescope is mounted directly on a dovetail bar, use the lower point as reference.
2. Manually adjust the telescope tube until the latitude scale reads 0 (Fig.h).
3. Next, the telescope must be pointing North from the location you are using.
4. After the above is accomplished, the Multi-Function Mount is now properly setup in the "Home" position.
5. Turn on the power.

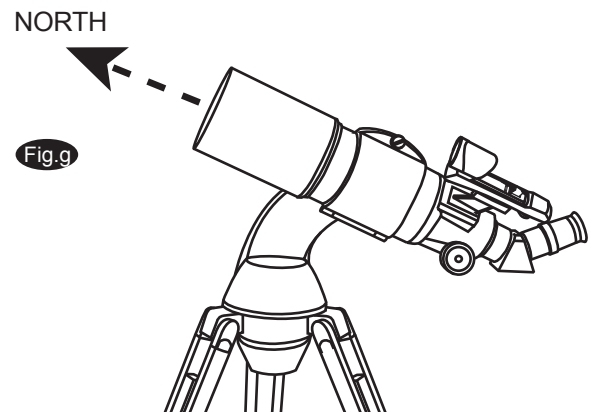
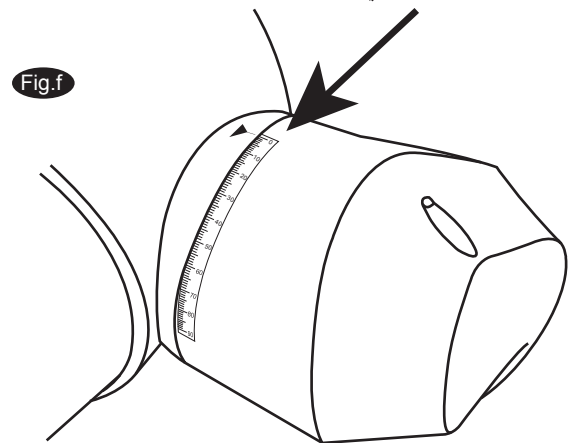
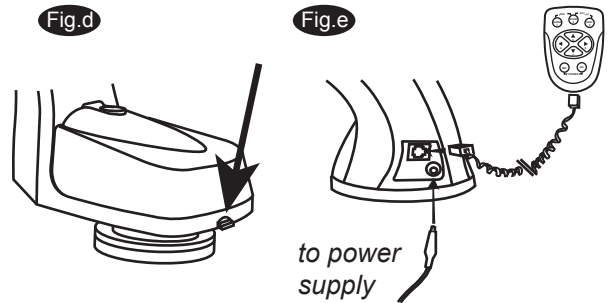

For telescope on the Mounting Platform or camera

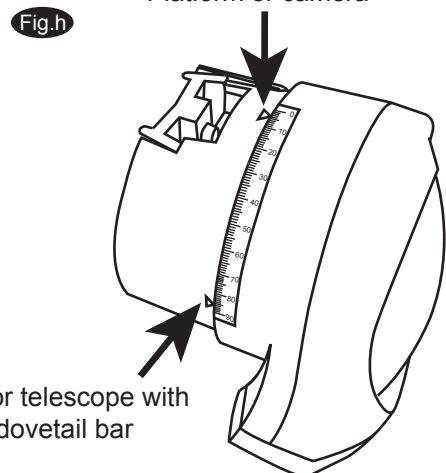

Setting the local latitude for accurate tracking

Setting the local latitude is not required to track an astronomical object but it greatly enhances the tracking accuracy. It requires that you know the latitude of the observing site. To set the latitude for the Northern Hemisphere, use the directional buttons to adjust the telescope tube until the latitude scale reads 0. Turn off the power and turn it back on again. Now use the hand control to move the telescope tube until the latitude scale reads your local latitude. Press the "Fast" and "Slow" buttons simultaneously to store the local latitude into the system (Fig.i).

For Southern Hemisphere, use the direction buttons to adjust the telescope tube until the latitude scale reads your local latitude. Turn off the power and turn it back on again. Now use the directional buttons to move the telescope tube until the latitude scale reads 0. Press "Fast" and "Slow" buttons simultaneously to store the local latitude into the system (Fig.i).

Setting the local latitude only needs to be done once. The information will be stored in the hand control even when the power is turned off.

Fig.i

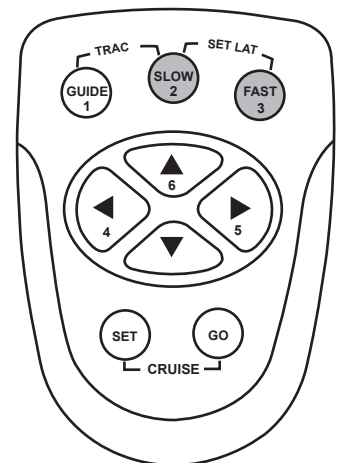

Use the same ▲ or ▼ key to end adjusting scale reading to 0 degree and setting your local latitude. This will help eliminate the influence of mechanical backlash. For example, if ▲ key is the last key that you used to set the scale to 0 degree, you should also use ▲ key as the last key for setting the scale reading to your local latitude.

Hand Control Operation

The basic movements of the telescope mount are directional movement, slewing, and tracking. The tracking rate is sidereal rate.



When a command is successfully entered, all the LEDs will light up. The LEDs will not go off until all key buttons are released. If there is any type of communication error between the hand control and the motor Assembly, all the LEDs will flash.

THE DIRECTIONAL KEYS (Fig.j) allow for the movement direction that you want the telescope to go. If two opposite buttons are pressed at the same time, only the button first pressed will respond. AZ (azimuth) and ALT (altitude) axis can be adjusted at the same time.

THE SLEWING SPEED (Fig.k) can be set from the three available options by pressing the correspondent key on the hand control:

Guide (default) -- slow speed used for centering objects in the eyepiece.

Slow -- medium speed used for finding and moving objects in the finderscope.

Fast -- fast speed used for quick movement in the sky.

The actual slewing speeds are different depending on whether tracking is "on" or "off". See the chart below for details. (1x = Sidereal rate)

Slewing Speeds	Guide	Slow	Fast
Tracking "on"	1x	4x	8x
Tracking "off"	32x	64x	800x



In standby mode, the LED will respectively indicate the current slewing speed.

Fig.j

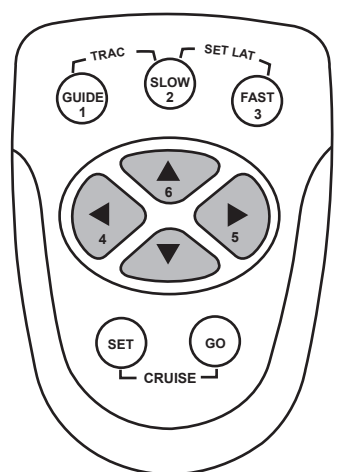
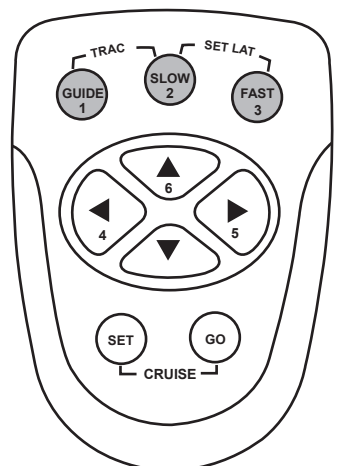
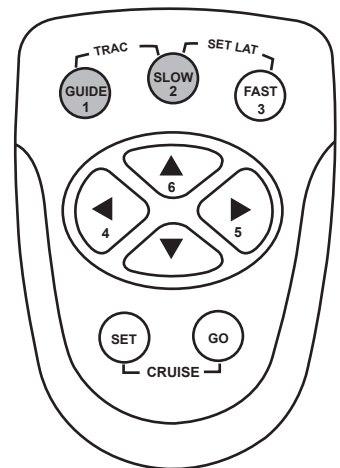

Fig.k



To activate the **TRACKING FUNCTION**, you must first find the astronomical object you are seeking. The preferred method of finding objects is called "star-hopping" and there is much written on this method. Remember, you must use the Hand Control unit to move the telescope as you cannot move it manually. When you are ready to track (when the object is in the center of the field of view), press the "Guide" and "Slow" buttons in combination and tracking will be activated (Fig.l). When you want to cancel "tracking" and slew in higher speed, press the same button combination. Note that when tracking is activated, one of the "Guide", "Slow" or "Fast" buttons will flash.

Fig.l



When the tracking is "on", use the Slow (4x) and Fast (8x) speeds to center objects in the eyepiece for astronomical objects. With tracking "off", use the Guide (32x) and Slow (64x) speeds to center astronomical objects in the finderscope, and the Fast (800x) for general slewing to get to objects quickly.

FOR TERRESTRIAL (LAND) USAGE

Setting up the telescope

The telescope does not require setup for terrestrial use. The telescope can start from any position. However, if the telescope is positioned in one spot and the Cruise function is utilized, setting a Reference Point to start and end a viewing session will save a lot of time for you --- you will not need to reset the 6 Cruising positions before every viewing session. The Reference Point is defined as the point to which the optical tube is pointing when the power switch is turned on. (See below for information on the Cruise function.)

Fig.m

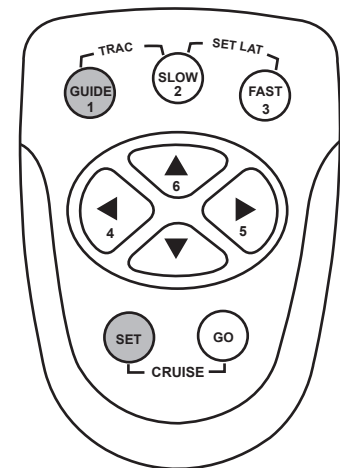

Make sure to turn off "Tracking" when using the Auto-tracking mount for terrestrial use.

Hand control operation

The Auto-Tracking Telescope can be set to automatically CRUISE between up to 6 stored positions, or GOTO any stored position.

STORING POSITIONS

You can store up to 6 positions. After slewing to a desired position using the directional keys, press "SET" and one of the 6 numeric keys (Fig.m). The location of each selected position will be stored in the system memory of the hand control until the data is overwrite by the user.

Fig.n

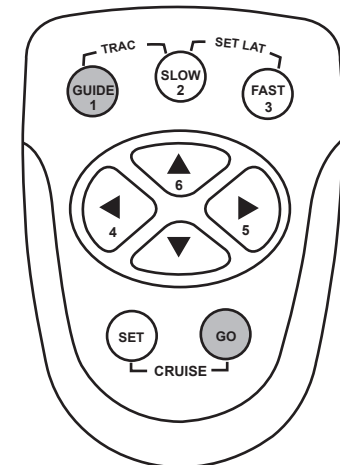

To ensure the best accuracy of your position choices, it is important that before the actual setting you do the final direction adjustments using the ▲ and ► keys.

"GOTO" A STORED POSITION

Once the stored positions are set you can GOTO them. Press "GO" and then the corresponding numeric key for the position desired (Fig.n). The mount will automatically slew to the stored position. Once the GOTO function is activated, both "GO" and the corresponding numeric key will light up.

CRUISE

The CRUISE mode is usable if you want the mount to stop for several seconds at each stored position during slewing. To activate the CRUISE function, press "SET" and "GO" keys in combination (Fig.o). The mount will cruise sequentially among the stored positions. The mount will stay in each position for 5 seconds and then move on to the next position. After one cycle, the mount will stop at the last position for 3 minutes and the cruising cycle will start over again. You can bypass the waiting period of 3 minutes by pressing the "fast" key and the cycle will then start right away.

Fig.o

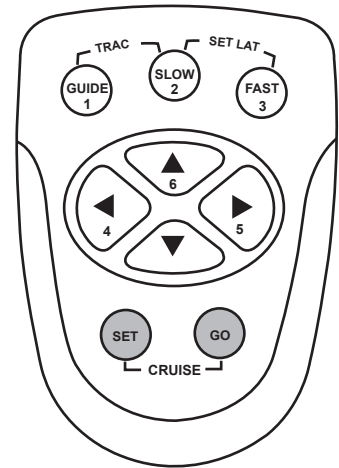

In the cruise mode, the "SET" and "GO" keys will remain lit throughout the cycle and the numeric key the mount is moving to will flash.



If the multifunction mount is connected to an Acuter digital spotting scope or Canon EOS digital camera (see Auto Imaging below), in the cruise mode, the mount will automatically send a signal for the digital imaging device to take a shot every time it reaches a stored position. If you do not wish to activate this function, simply remove the connecting cable between the multifunction mount and the digital imaging device.

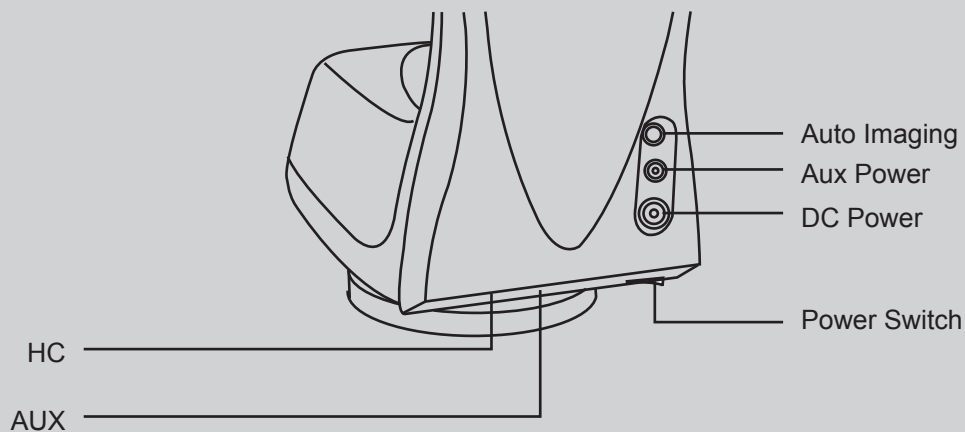

Auto Imaging — Electronic shutter interface. This controls software action from the mount to devices such as digital spotting scope or Canon EOS digital cameras.

AUX Power — Power supply socket for other devices. This is for auxiliary power from the mount to devices such as digital spotting scope or digital camera. The output voltage is the same as DC power.

DC Power — For optional DC 12-volt source to power the mount.

HC — For connection to the hand control.

AUX — Not in use.

SCAN

The SCAN function allows for scanning among all the stored positions one by one without a stop at each position. There is not waiting at the end of each scan cycle. Hold the "GO" key and press the ▼ key to activate the "SCAN" function (Fig.p).

ERASE A STORED POSITION

If you want to permanently erase a set position, return the mount to the Reference Position. Turn the power off and then turn it back on again. Hold down the "SET" button and press the numeric key corresponding to the position you want to erase. This is to override the previous stored information with 0. In the CRUISE and SCAN modes, the mount will recognize this and bypass this position and go to the next position instead.



The mount allows a total of 6 stored positions. If there is a vacant one available, it is recommended that you store the Reference Position for quick access in the future.



To stop the mount during "GOTO", "Cruise", and "Scan" functions, press the ► and ▼ keys simultaneously (Fig.q). After a command has been implemented, all keys have to be released before the mount accepts the next command. During the "GOTO", "Cruise", and "Scan", the mount only reacts to the stop key combination.

Fig.p

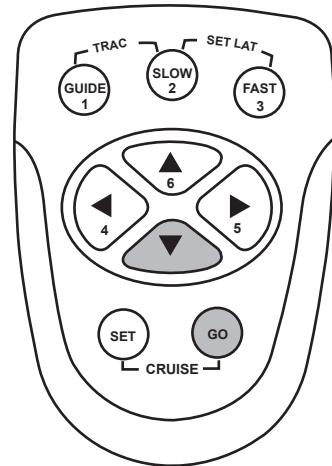
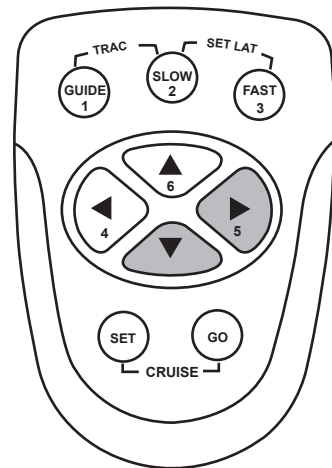

Fig.q



CAUTION!



NEVER USE YOUR TELESCOPE TO LOOK DIRECTLY AT THE SUN. PERMANENT EYE DAMAGE WILL RESULT. USE A PROPER SOLAR FILTER FIRMLY MOUNTED ON THE FRONT OF THE TELESCOPE FOR VIEWING THE SUN. WHEN OBSERVING THE SUN, PLACE A DUST CAP OVER YOUR FINDERSCOPE OR REMOVE IT TO PROTECT YOU FROM ACCIDENTAL EXPOSURE. NEVER USE AN EYEPiece-TYPE SOLAR FILTER AND NEVER USE YOUR TELESCOPE TO PROJECT SUNLIGHT ONTO ANOTHER SURFACE, THE INTERNAL HEAT BUILD-UP WILL DAMAGE THE TELESCOPE OPTICAL ELEMENTS.