

# INSTRUCTION MANUAL

## FOR 2001PEQ5

Optical Tube: 200mm/1000mm Equatorial Mount: EQ5

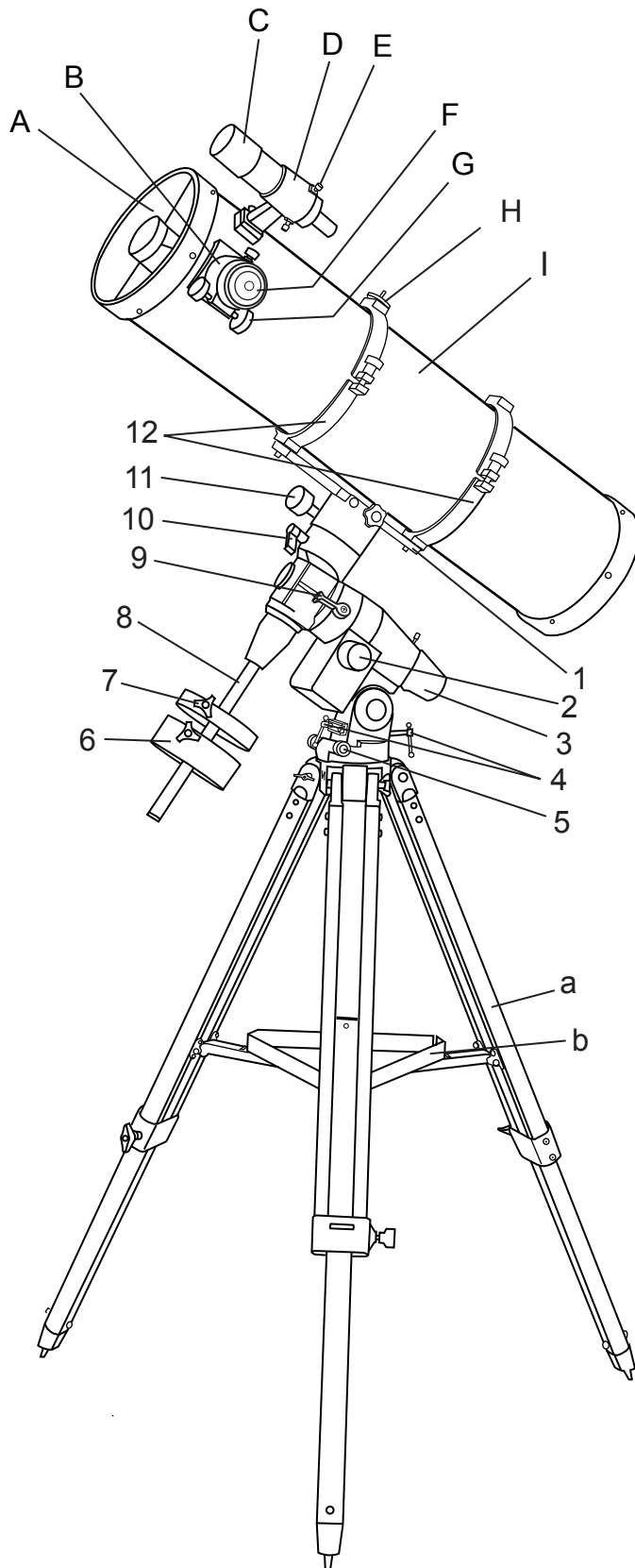

**Sky-Watcher**

- A. Dust Cap (not shown)  
Remove before Viewing
- B. Focus Tube
- C. Finderscope Bracket
- D. Finderscope
- E. Finderscope Adjustment  
Screws
- F. Eyepiece
- G. Focus Knob
- H. Piggyback Bracket
- I. Telescope Main Body

- 1. Mounting Plate
- 2. R.A. Control Knob
- 3. Polarscope Holder  
(not shown)
- 4. Altitude Adjustment T-bolts
- 5. Azimuth Adjustment Knob
- 6. Counterweight
- 7. Counterweight Thumb  
Screw
- 8. Counterweight Knob
- 9. R.A. Lock Level
- 10. Dec. Lock Level
- 11. Dec. Control Knob
- 12. Tube Rings

- a. Accessory Tray
- b. Tripod Leg

# TABLE OF CONTENTS

<b>Assembling Your Telescope</b> .....	<b>3</b>
Tripod Set up .....	3
Telescope Assembly .....	3
Finderscope Assembly .....	4
Eyepiece Assembly .....	4
<b>Operating Your Telescope</b> .....	<b>5</b>
Aligning the Finderscope .....	5
Balancing Telescope .....	5
Using the Equatorial Mount (EQ5) .....	6
Using the Oculars .....	6
Proper Care for Your Telescope .....	6
<b>Suggested Reading</b> .....	<b>7</b>

## Before you begin

Follow the instructions for your specific model in the manual. Read the entire instructions carefully before beginning. Your telescope should be assembled during daylight hours. Choose a large, open area to work to allow room for all parts to be unpackaged.

## Caution!

Never use your telescope to look directly at the sun. Permanent eye damage will result. Use a proper solar filter for viewing the sun. When observing the sun, place a dust cap over your finderscope to protect it from exposure. Never use an eyepiece-type solar filter and never use your telescope to project sunlight onto another surface, the internal heat build-up will damage the telescope optical elements.

## Technical Specifications

<i>Optical Design</i>	Acromatic Refractor
<i>Diameter</i>	200mm
<i>Focal Length</i>	1000mm
<i>f/ratio</i>	f/5
<i>Highest Practical Power</i>	400x
<i>Fainest Steller Magnitude</i>	14.2□
<i>Resolving Power (arc sec.)</i>	0.6□
<i>Finderscope</i>	9x50
<i>Focuser Diameters</i>	2" with 1.25" adapter
<i>Mount Type</i>	Equatorial
<i>Slow Motion Control</i>	RA & DEC
<i>Accessory Tray</i>	Large
<i>Tripod</i>	Aluminum
<i>Tube Dimensions</i>	24cm x 90cm
<i>Tripod Height</i>	71-123cm
<i>Total Net Weight</i>	29kgs
<i>Shipping Weight</i>	23.2+14.8kgs (2 cartons)

## Technical Support

Canada: 604-270-2813  
between 9:00AM and 3:00PM PST  
Outside Canada: Please contact your dealer for technical support.

If you are interested in submitting telephotographs taken with Sky-Watcher telescopes, or articles concerning any Sky-Watcher products, please call us at 604-241-7027.

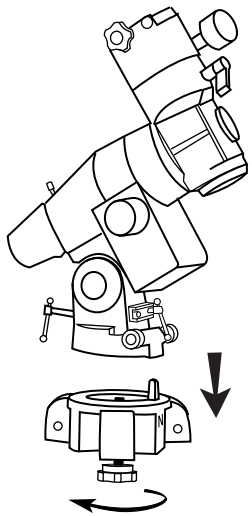

1.

### SETTING UP TRIPOD (1), (2)

- 1) Locate equatorial mount/tripod head.
- 2) Locate and loosen the knurled knob at bottom of the mount to separate the tripod head.
- 3) Lie tripod head on its side. Fasten the tripod legs to tripod head using the machine screws. Use the screwdriver provided and do not over-tighten the fasteners.

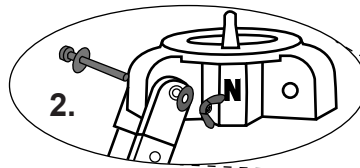

2.

3.

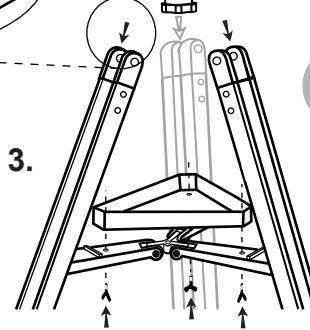

## TRIPOD SET UP

### INSTALLING ACCESSORY TRAY (3)

- 1) Locate tripod leg brace.
- 2) Use the screws already attached to the hinges to mount the tray platform.
- 3) Attach eyepiece/accessory tray to hinges on tripod legs using the small machine screws and wing nuts. Flange fits under accessory tray when attached.

### ATTACHING MOUNT TO TRIPOD (4)

- 1) Stand tripod upright.
- 2) Align metal dowel on the tripod head with the gap between the azimuthal adjustment knobs underneath the mount. Tighten the knurled knob underneath the tripod head to secure mount to tripod.

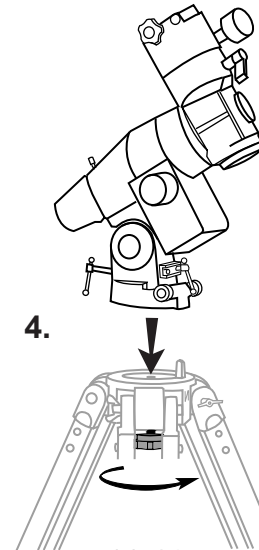

4.

Note: Loosen the azimuthal adjustment knobs if mount does not fit into tripod head completely. Retighten knobs to secure.

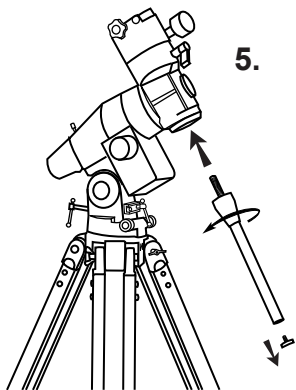

5.

### INSTALLING COUNTERWEIGHT (5), (6)

- 1) Locate counterweight rod.
- 2) Screw counterweight rod into threaded on the end of the declination shaft. Tighten locknut on counterweight rod until it is locked against the mount.
- 3) Unscrew the threaded cap from the end of the counterweight rod.
- 4) Locate counterweights and slide them halfway along counterweight rod. Tighten counterweight thumbs to secure.
- 5) Replace cap on the end of counterweight rod.

6.

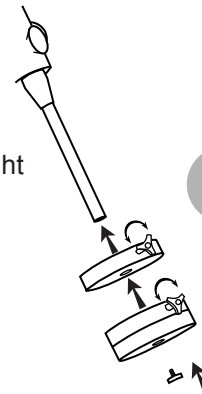

## TELESCOPE ASSEMBLY

### ATTACHING THE MOUNTING PLATE (7)

- 1) Position mounting plate on mounting bracket.
- 2) Secure by tightening the two locking screws.

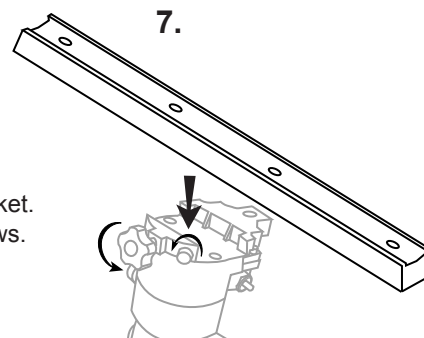

7.

# TELESCOPE ASSEMBLY

## ATTACHING THE TUBE RINGS TO MOUNT(8)

- 1) Remove the telescope tube from its plastic packaging.
- 2) Remove the tube rings from telescope by releasing their thumb nuts and opening their hinges.
- 3) Using the bolts provided, fasten the tube rings to the mount with the 10mm wrench provided.

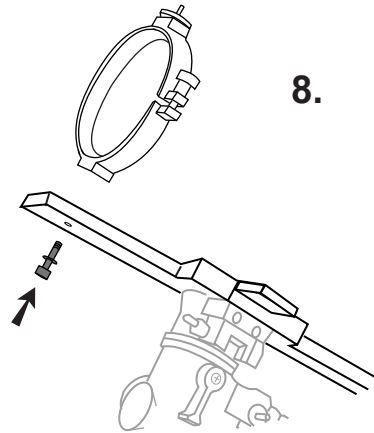

8.

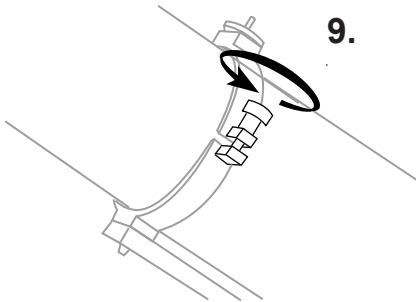

9.

## ATTACHING THE TELESCOPE MAIN TUBE TO TUBE RINGS (9)

- 1) Remove the telescope tube from the paper covering.
- 2) Find the center of balance of the telescope tube. Place this in between the two tube rings. Close the hinges around the telescope and fasten securely by tightening the thumb nuts. □

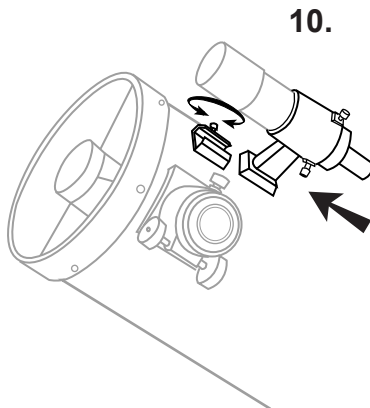

10.

## ATTACHING THE FINDER-SCOPE BRACKET (10)

- 1) Locate finderscope optical assembly.
- 2) Slide finderscope bracket into the rectangular slot and tightened screw to hold mount in place.

# FINDERSCOPE ASSEMBLY

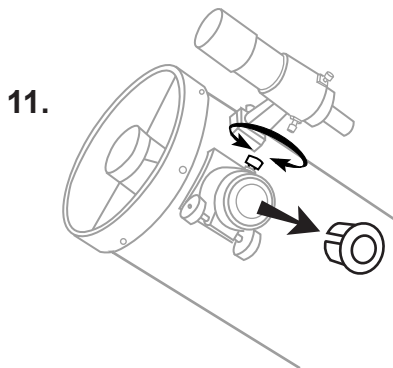

11.

## INSERTING EYEPIECE (11), (12)

- 1) Unscrew the thumbscrews on the end of the focus tube to remove the black plastic end-cap.
- 2) Re-tighten thumb screws to hold eyepieces in place.

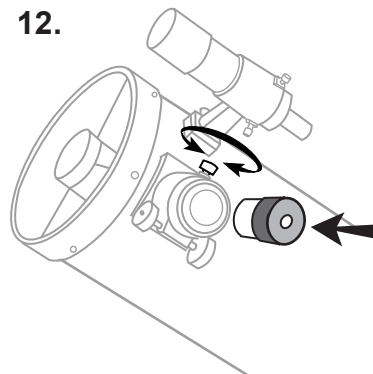

12.

# EYEPIECE ASSEMBLY

# OPERATING YOUR TELESCOPE

## Aligning the Finderscope

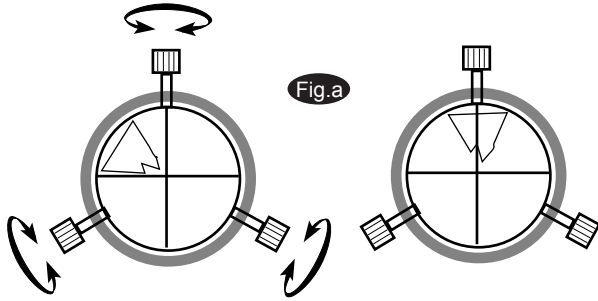

- 1) Focus the telescope eyepiece on a distant object.
- 2) Once the object has been centered in the telescope view, ensure all the lock knobs on the mount are tightened.
- 3) Use the alignment screws to center the finderscope crosshairs on the object seen in the telescope view (Fig.a).

Depending on telescope design, the object may appear inverted in the telescope view.  
Do not over-tighten the alignment screws.

## Balancing telescope

Telescope should be balanced before each observing session. Balancing reduces stress on telescope mount and allows precise control of micro-adjustment. A balanced telescope is specially critical when using the optional clock drive for astrophotography.

The telescope should be balanced after all accessories (eyepiece, camera, etc.) have been attached. Before balancing your telescope, make sure that your tripod is balanced and on a stable surface. For photography, point the telescope in the direction you will be taking photos before performing the balancing steps.

### R.A. Balancing

- 1) Adjust altitude of the mount to between  $15^\circ$  and  $30^\circ$  by using the altitude adjustment T-bolt.
- 2) Slowly unlock the R.A. and Dec thumbscrews. Rotate the telescope until both the optical tube and counterweight rod is horizontal to the ground, and the telescope tube is to the side of the mount (Fig.b).
- 3) Tighten the Dec. thumbscrew.
- 4) Move counterweight along counterweight rod until telescope is balanced and remains stationary when released.
- 5) Tighten set screws to hold counterweights in their new position.

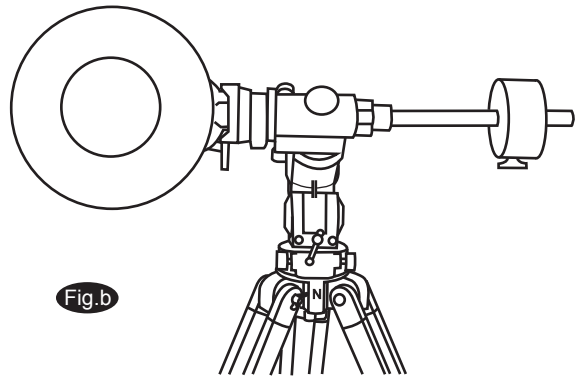

### Dec. Balancing

All accessories should be attached to the telescope before commencing with balancing the declination axis. The R.A. axis should be balanced before proceeding with dec. balancing.

- 1) Adjust altitude of the mount to between  $60^\circ$  and  $75^\circ$ .
- 2) Release the R.A. thumbscrew and rotate R.A. axis so that the counterweight rod is in horizontal position. Tighten the R.A. thumbscrew.
- 3) Unlock the Dec. thumbscrew and rotate telescope tube until it is parallel to the ground.
- 4) Slowly release telescope and determine which direction the telescope rotates. Loosen telescope tube clamps and slide telescope tube forward or backward in the clamps to balance dec. axis.
- 5) Once telescope no longer rotates from its parallel starting position, re-tighten tube clamps and the Dec. thumbscrew. Reset altitude axis to your local latitude.

## Using the leveling bubble

For best telescope performance, the equatorial mount should be properly leveled. A level tripod allows easier fine adjustment of controls and better weight distribution.

This equatorial mount includes a small leveling bubble near its base (Fig.c). Adjust the height of each tripod leg until the bubble appears in the center of the circle. Note that the tripod legs may not be at same length when the equatorial mount is level.

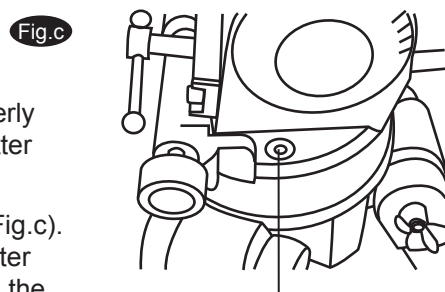

Leveling bubble

# OPERATING YOUR TELESCOPE

## Using the EQ5 mount

The equatorial mount has controls for both conventional altitude (up-down) and azimuthal (left-right) directions of motion. Use the altitude adjustment T-bolts for altitude adjustments. These allow fine-adjustment for setting the mount to your local latitude. The azimuthal axis is changed by the two azimuth adjustment knobs located near the tripod head. These allow fine-adjustment of azimuth for polar aligning. For large azimuth direction change, lift up and rotate the tripod (Fig.d).

In addition, this mount has direction controls for polar-aligned astronomical observing. These directions use right ascension (east/west) and declination (north/south) axis. There are two options to move the telescope in these directions: For large and quick movement, loosen the R.A.lock level under the R.A. shaft or the Dec. lock level near the top of the mount. For fine adjustments, use the control cable/nob near each axis (Fig.e).

There are three numerical scales on this mount. The lower scale is for the altitude axis and is used for polar-alignment of the telescope to your local latitude (Fig.f). The R.A. (right ascension) vernier scale is measures hour angle and is adjustable to your local meridian. The declination scale is located near the top of the mount (Fig.g).

The tripod can be separated from the mount and telescope by unscrewing the large knob underneath the tripod head.

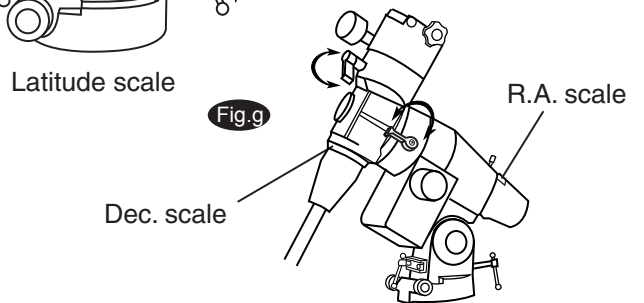
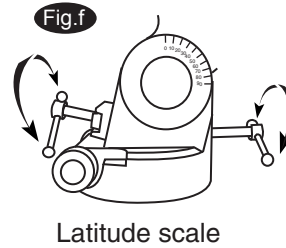
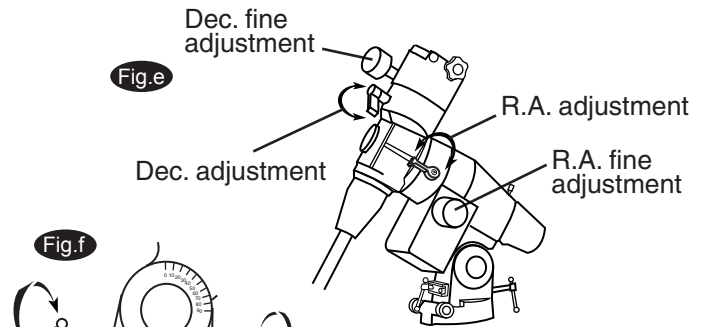
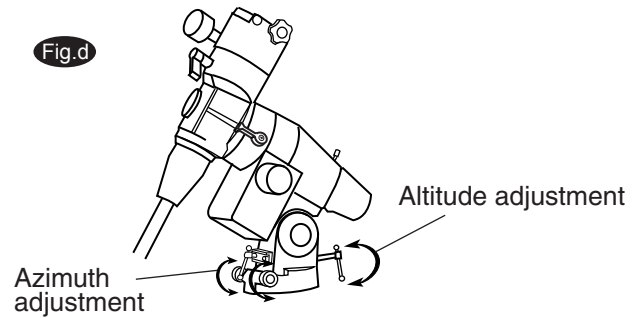

## Using the oculars

To magnify images in the telescope, you need to insert an eyepiece (ocular) into the end of the focuser assembly. Insert the desired eyepiece and lightly tighten the thumbscrews to hold the eyepiece in place. Barlow lens can be used to increase magnification of the eyepiece. Install the barlow lense directly into the end of the focuser, then insert the eyepiece into the barlow lense. (Fig.h)

To locate an object in the eyepiece, first locate the object in the finderscope view. The finderscope allows magnification of a larger area than the higher power telescope view. Finderscope should be aligned during daytime before use.

The focus knobs at the base of the focuser uses a rack-and-pinion system to focus the magnified images seen through the telescope. Turn the knobs slowly until the objects are in focus.

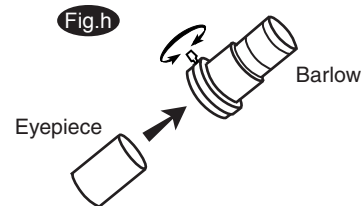

## Proper care for your telescope

Replace the dust cap over end of telescope whenever not in use. This prevents dust from settling on mirror or lens surface. Do not clean mirror or lens unless you are familiar with optical surfaces. Clean finderscope and eyepieces with special lens paper only. Cleaning and aligning of optical elements should be performed by an experienced technician every two years. Eyepieces should be handled with care, avoid touching optical surfaces.

Telescopes require about 30 minutes to equalize with surrounding temperature and humidity. This minimizes heat wave distortion inside telescope tube and allows telescope to adapt to ambient moisture conditions.

# SUGGESTED READING

## Amateur Astronomy

### **Beginner's Guide to Amateur Astronomy:**

An Owner's Manual for the Night Sky by David J. Eicher and, Michael Emmerich (Kalmbach Publishing Co., Books Division, Waukesha, WI, 1993).

**NightWatch: A Practical Guide to Viewing the Universe** by Terence Dickinson, (Firefly Books, Willowdale, ON, Canada, 3rd edition, 1999).

**Star Ware: The Amateur Astronomer's Ultimate Guide to Choosing, Buying, and Using Telescopes and Accessories** by Philip S. Harrington (John Wiley & Sons, New York, 1998 ).

**The Backyard Astronomer's Guide** by Terence Dickinson and Alan Dyer (Firefly Books Ltd., Willowdale, ON, Canada, revised edition, 1994).

**The Beginner's Observing Guide: An Introduction to the Night Sky for the Novice Stargazer** by Leo Enright, (The Royal Astronomical Society of Canada, Toronto, ON, Canada, 1999).

**The Deep Sky: An Introduction** by Philip S. Harrington (Sky Publishing Corporation, Cambridge, MA, Sky & Telescope Observer's Guides Series, ed. Leif J. Robinson, 1997).

**The Universe from Your Backyard: A Guide to Deep Sky Objects** by David J. Eicher (Kalmbach Publishing Co., Books Division, Waukesha, WI, 1988).

**Turn Left at Orion: A Hundred Night Sky Objects to See in a Small Telescope--and how to Find Them** by Guy J. Consolmagno and Dan M. Davis, (Cambridge University Press, New York, 3rd edition, 2000)

## Astrophotography

**A Manual Of Advanced Celestial Photography** by Brad D. Wallis and Robert W. Provin (Cambridge University Press; New York; 1984)

**Astrophotography An Introduction** by H.J.P. Arnold (Sky Publishing Corp., Cambridge, MA, Sky & Telescope Observer's Guides Series, ed. Leif J. Robinson, 1995).

### **Astrophotography for the Amateur**

by Michael Covington (Cambridge University Press, Cambridge, UK, 2nd edition, 1999).

**Splendors of the Universe: A Practical Guide to Photographing the Night Sky** by Terence Dickinson and Jack Newton (Firefly Books, Willowdale, ON, Canada, 1997)

**Wide-Field Astrophotography** by Robert Reeves (Willmann-Bell, Inc., Richmond, VA, 2000).

## Observational References

**A Field Guide to the Stars and Planets** by Jay M. Pasachoff, (Houghton Mifflin Company, 1999).

**Atlas of the Moon** by Antonín Růkl (Kalmbach Publishing Co., Books Division, Waukesha, WI, 1993).

**Burnham's Celestial Handbook: An Observer's Guide to the Universe Beyond the Solar System** by Robert Burnham (Dover Publications, New York; 3- volume set, 1978).

**Observer's Handbook** by The Royal Astronomical Society of Canada, (University of Toronto Press, Toronto, ON, Canada, published annually).

**Sky Atlas 2000.0** by Wil Tirion and Roger W. Sinnott (Sky Publishing Corp., Cambridge, MA, 2nd edition, 1998)

## Magazines

**Astronomy Magazine** (Kalmbach Publishing Co., Waukesha, WI)

**Sky & Telescope Magazine** (Sky Publishing Corp., Cambridge, MA)

**SkyNews Magazine: The Canadian Magazine of Astronomy & Stargazing** (SkyNews Inc., Yarker, ON, Canada)