

USING THE POLAR SCOPE FOR EQ3-2 & EQ4

The Polar Alignment Finderscope or 'polarscope' gives Northern Hemisphere users a convenient tool for pointing at the NCP. It has a large circle circumscribing the path of Polaris, with the NCP located at the crosshair, and it has a smaller circle to indicate the direction of Polaris. However, the Earth rotates and the orientation of the stars changes, so a method is needed to obtain the correct alignment of Polaris in the polarscope, for the date and time of your viewing session.

Aligning the polarscope to the mount's polar axis:

This is most easily done by pointing at a terrestrial target with the RA drive turned off. To allow full rotation around the RA axis, remove the telescope and the counterweight, including the rod. Unlock the Dec clutch and rotate to Dec 0°, then lock the Dec clutch. Remove the cap from the bottom of the RA axis shaft and the plug from the top (Fig.a).

At the bottom of the polar shaft is a black, 24-hour clock dial. The top row of numbers is for Northern Hemisphere use, the lower for the Southern Hemisphere. Unlock the setscrew just above it and rotate the dial until zero is aligned with the indicator cast into the metal just below the screw. Tighten the setscrew to lock the dial (Fig.b).

The silver dial just below it is a calendar dial. The months are numbered 1-12. The longest lines separate the months, the middle-length lines are ten days apart, and the short lines between them are two days apart.

The black collar holding this silver dial in place, has an indicator line inscribed on it. The numbers nearest this collar are marked "E 20 10 0 10 20 W". These will be explained later, but for now rotate the silver dial until the middle zero is aligned with the indicator line on the black collar.

At midnight on November 1, on the Central Meridian of your local time zone, Polaris is directly above the NCP. It is therefore directly below when viewed through the inverted view of the polarscope. This provides a good way to orient the polarscope in the mount.

Unlock the R.A. clutch and rotate the mount in R.A. until 'November 1' (long line between 10 and 11) on the calendar dial is lined up with '0' (midnight) on the 24-hour clock dial, then lock the clutch again (Fig.c). Loosen the three polarscope alignment screws.

Look into the polarscope and you will see a crosshair with a circle surrounding it and a smaller circle off on one of the arms (Fig.c). Turn the polarscope until the little offset circle is at the bottom and then slide it into the polarscope holder, lined up with the zero on the clock dial. Insert the polarscope far enough so that later it will not interfere with the protective cap.

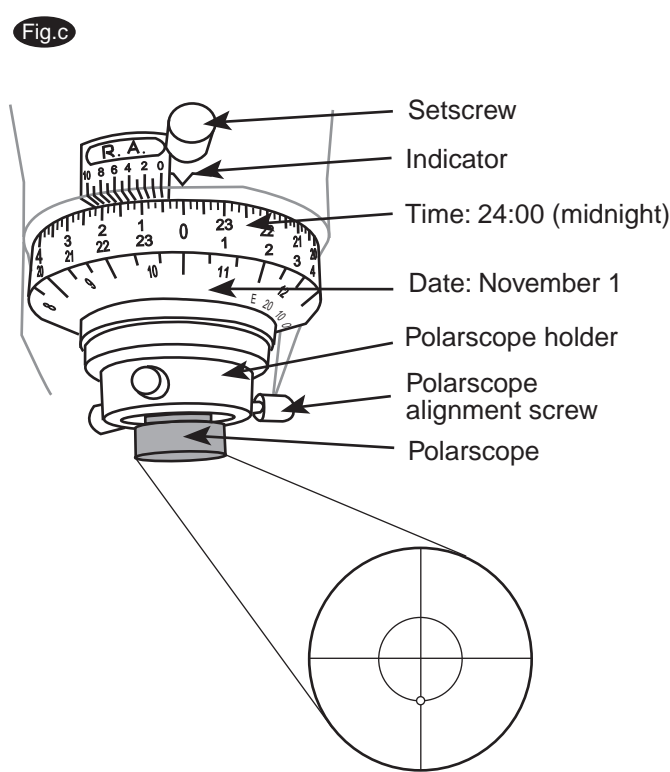
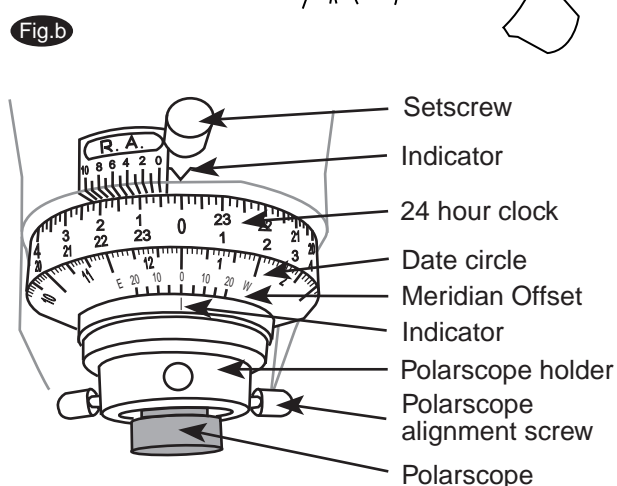
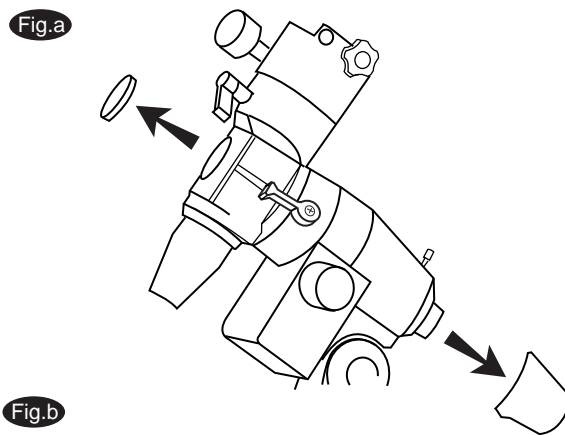

Once you have it inserted you will have to centre it. The easiest way to do this is to lower the mount head in azimuth and sight on a distant object in daylight. This may involve taking out the latitude t-screw, shortening one leg, or both to get the head down low enough. After you have done this unlock the R.A. clutch again and rotate the mount back and forth in R.A. while keeping your target in view. The idea is to gently tweak the three alignment screws, while rotating the mount, until the target remains at the centre of rotation. This shouldn't take long and after that keep the plastic cap on to protect it from getting bumped off alignment. Set the azimuth of the mount back to the correct latitude.

Using the polarscope:

1. Now about the numbers "E 20 10 0 10 20 W". First, you need to find your present Longitude. You can do this by consulting a map, chart, GPS, etc. The idea is to find how far east or west your viewing site is from the reference meridian for your time zone. For example, the Longitude of Vancouver, BC is 123° and the reference meridian for the Pacific Time Zone is 120°, so the setting will be 3° W. The lines on the dial are 5° apart so rotate the silver dial until the indicator on the black collar points between the zero and 5° line (Fig.d). If you observe from a significantly different longitude, this setting will have to be changed.

Fig.d



2. At your viewing site, set the mount (without weights and scope) facing North. Adjust it to a convenient height for viewing and carefully level it. Unlock the Dec clutch and rotate to Dec 0°, then lock the Dec clutch. Remove the cap from the bottom of the RA axis shaft and the plug from the top.
3. Set the black 24-hour clock dial so that the hour '0' aligns with the top indicator, and lock it in place with the setscrew. Remember this dial is a clock face running from 0-23 hours. Northern hemisphere users use the top row of numbers and all times are in Standard Time. Do not use Daylight Saving Time for the following setting.
4. Unlock the R.A. clutch, and rotate the mount in R.A. until the current date on the silver calendar dial, is aligned with the current time using the black 24-hour clock dial (Standard Time), then lock the R.A. clutch.
5. Using only the latitude adjustment t-screws for up and down, and the azimuth adjustment off-set screws on the north side of your mount for left-right, centre Polaris in the little offset circle. You may have to shine your red flashlight at an angle across the front to illuminate the crosshair or better yet have a friend hold the light while you do the adjustments.
6. Lastly, loosen the top setscrew, unlock the R.A. clutch, put on the counterweights and then the scope and finally adjust the balance position of the counterweight.