

INSTRUCTION MANUAL

FOR 705AZ3

Optical Tube: 70mm/500mm

Alt-Azimuth Mount: AZ3

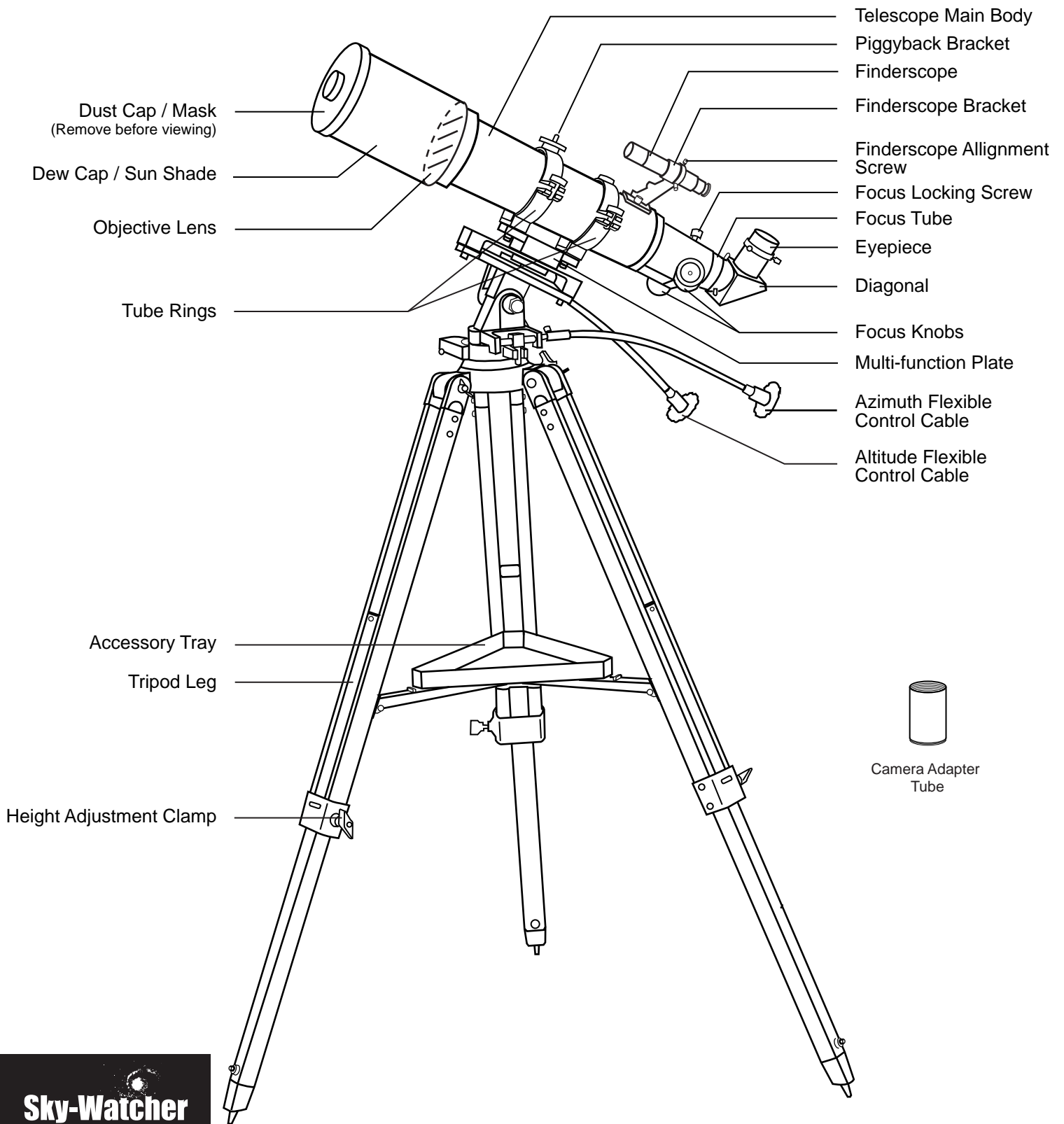

TABLE OF CONTENTS

Assembling Your Telescope	3
Tripod Set up	3
Telescope Assembly	3
Finderscope Assembly	4
Eyepiece Assembly	4
Aligning the Finderscope	4
Operating Your Telescope	5
Operating the AZ3 Mount	5
Using the Barlow Lens	5
Focusing	5
Using the Camera Adapter Tube	6
Pointing Your Telescope	6
Calculating the Magnification (power)	7
Calculating the Field of View	7
Calculating the Exit Pupil	7
Observing the Sky	8
Sky Conditions	8
Selecting an Observing Site	8
Choosing the Best Time to Observe	8
Choosing the Telescope	8
Using Your Eyes	8
Suggested Reading	9

Before you begin

Read the entire instructions carefully before beginning. Your telescope should be assembled during daylight hours. Choose a large, open area to work to allow room for all parts to be unpackaged.

Caution!

Never use your telescope to look directly at the sun. Permanent eye damage will result. Use a proper solar filter for viewing the sun. When observing the sun, place a dust cap over your finderscope to protect it from exposure. Never use an eyepiece-type solar filter and never use your telescope to project sunlight onto another surface, the internal heat build-up will damage the telescope optical elements.

TRIPOD SET UP

Fig. 1

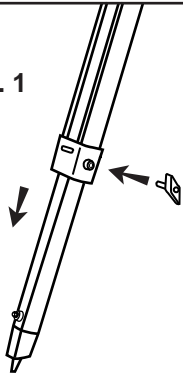

ASSEMBLING TRIPOD LEGS (Fig. 1)

- 1) Gently push middle section of each tripod leg at the top so that the pointed foot protrudes below the tripod clamp.
- 2) Insert tripod lock screws into the thread holes on the side of the tripod clamp without over-tightening.

Fig. 2.

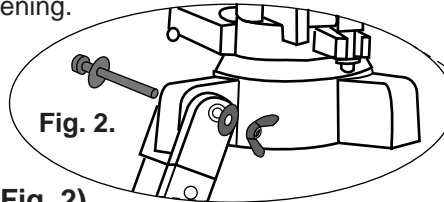

ATTACHING MOUNT TO TRIPOD LEGS (Fig. 2)

- 3) Fasten the top of each tripod leg to the bottom of the yoke mount using the machine screws with the washers and wingnuts. Align each leg so that the hinge for the accessory tray faces inwards. Be careful not to over-tighten the wingnuts and damage tripod legs.

ATTACHING THE ACCESSORY TRAY (Fig. 3)

- 1) Locate tripod leg brace.
- 2) Use the screws already attached to the tripod hinges to mount the tray platform.
- 3) Secure the accessory tray on top of the tray platform using the thumbscrews already attached.

Fig. 3

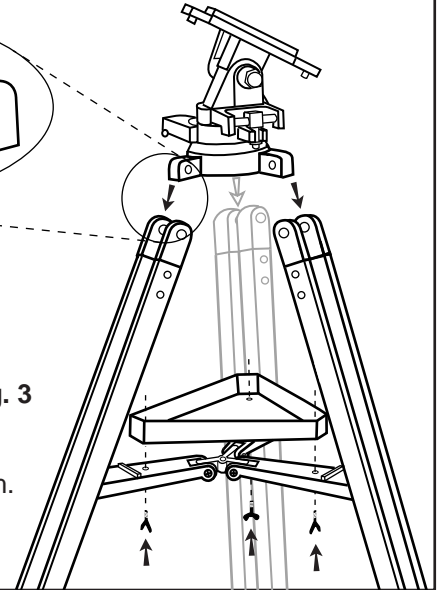

TELESCOPE ASSEMBLY

ATTACHING THE TUBE RINGS TO MOUNT (Fig. 4)

- 1) Remove the tube rings-multifunction plate assembly from telescope by releasing their thumbnuts and opening their hinges.
- 2) Using one of the three threaded holes in the multif-function pate ring-plate assembly to the mounting platform. Turn the knurled black wheel directly underneath the mounting platform on the alt-az mount while holding the tube rings in place to secure the telescope in place.

Fig. 4.

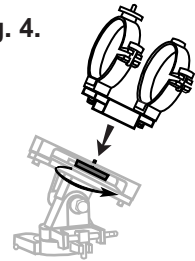

ATTACHING THE TELESCOPE MAIN TUBE TO TUBE RINGS (Fig. 5)

- 1) Remove the telescope tube from the paper covering.
- 2) Place telescope tube in between the two tube rings. Close the hinges around the telescope and fasten securely by tightening the thumb nuts without over-tightening.

Fig. 5

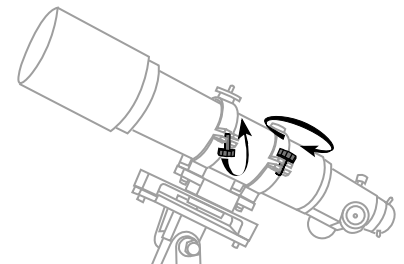

INSTALLING CONTROL CABLES (Fig. 6)

- 1) Slide the sleeve end of the cable over the nipple on the end of the worm gear. Secure the cable by tightening the set screw against the flat surface on the nipple.

Fig. 6.

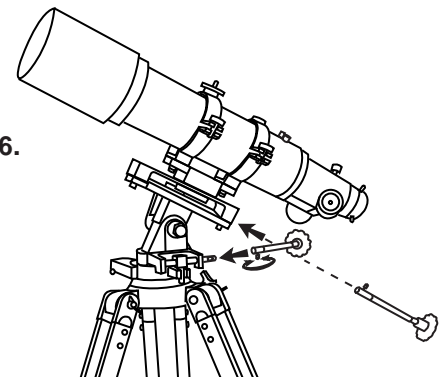

FINDERSCOPE ASSEMBLY

ATTACHING THE FINDERSCOPE (Fig. 7, 8)

- 1) Locate finderscope optical assembly.
- 2) Remove the two knurled thumbscrews near the end of the telescope main tube.
- 3) Position the finderscope bracket over the screws in the telescope main body.
- 4) Secure the finderscope bracket with the two knurled thumbscrews.

Fig. 7

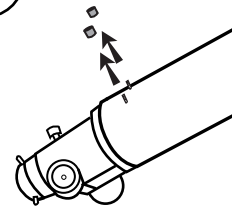
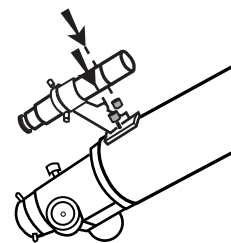

Fig. 8



EYEPIECE ASSEMBLY

INSERTING EYEPIECE (Fig. 9)

- 1) Unscrew the thumbscrews on the end of the focus tube to remove the plastic endcap.
- 2) Insert diagonal and re-tighten thumbscrews to hold diagonal in place.
- 3) Loosen the thumbscrews on the diagonal.
- 4) Insert the desired eyepiece into diagonal and secure by re-tightening thumbscrews.

Fig. 9

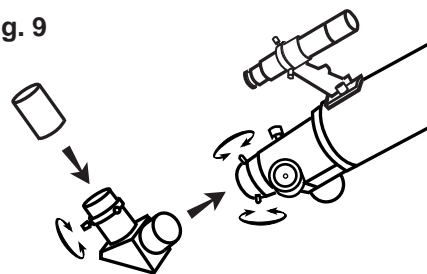

FINDERSCOPE ALIGNMENT

These fixed magnification scopes mounted on the optical tube are very useful accessories. When they are correctly aligned with the telescope, objects can be quickly located and brought to the centre of the field. Alignment is best done outdoors in day light when it's easier to locate objects. If it is necessary to refocus your finderscope, sight on an object that is at least 500 yards (metres) away. Twist the end of the finderscope until focus is reached (Fig.10).

Fig. 10

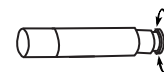

- 1) Choose a distant object that is at least 500 yards away and point the main telescope at the object. Adjust the telescope so that the object is in the centre of the view in your eyepiece.
- 2) Check the finderscope to see if the object centred in the main telescope view is centred on the crosshairs.
- 3) Use the three alignment screws to centre the finderscope crosshairs on the object (Fig.11).

Fig. 11

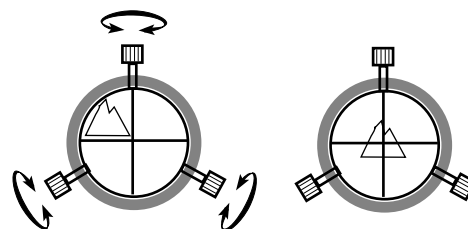

OPERATING YOUR TELESCOPE

Operating the AZ3 mount

This mount has controls for movement in altitude (up-down) and azimuth (left-right). Coarse azimuth movement is controlled by a locking knob located near the tripod head for left-right rotation. Loosen the knob to make large direction changes then lock it for fine adjustments. Coarse Altitude movement is controlled by a friction bolt. Use the micro-adjustment control cables to make small altitude and azimuth movements such as centring objects in view. The microadjustment controls have limited travel so it is best to centre them on their threads before making a coarse adjustment. (Fig. a)

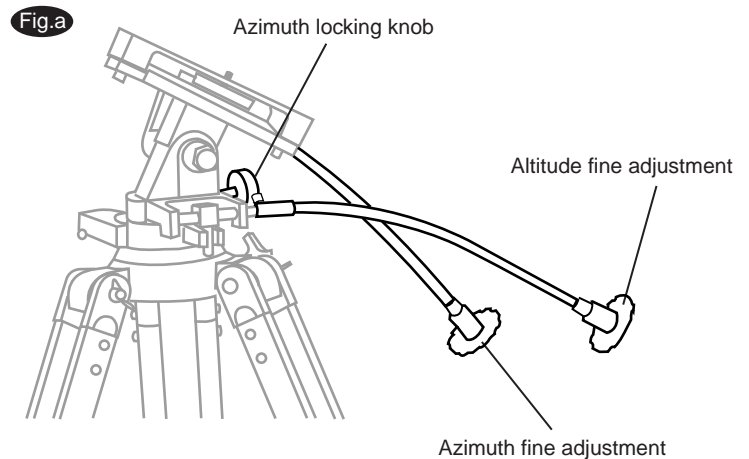

Using the Barlow lens

A Barlow is a negative lens which increases the magnifying power of an eyepiece, while reducing the field of view. It expands the cone of the focussed light before it reaches the focal point, so that the telescope's focal length appears longer to the eyepiece.

The Barlow is usually inserted between the diagonal and the eyepiece (Fig.b). With some telescopes, it can also be inserted between the focuser and the diagonal, and in this position it gives even greater magnification. For example, a Barlow which is 2X when inserted after the diagonal can become 3X when placed in front of the diagonal.

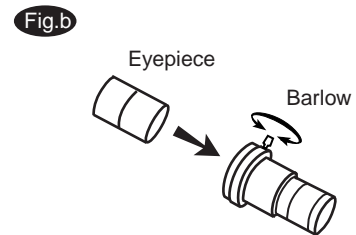

In addition to increasing magnification, the benefits of using a Barlow lens include improved eye relief, and reduced spherical aberration in the eyepiece. For this reason, a Barlow plus a lens often outperform a single lens producing the same magnification. However, its greatest value may be that a Barlow can potentially double the number of eyepiece in your collection.

Focusing

Slowly turn the focus knobs under the focuser, one way or the other, until the image in the eyepiece is sharp (Fig.c). The image usually has to be finely refocused over time, due to small variations caused by temperature changes, flexures, etc. This often happens with short focal ratio telescopes, particularly when they haven't yet reached outside temperature. Refocusing is almost always necessary when you change an eyepiece or add or remove a Barlow lens.

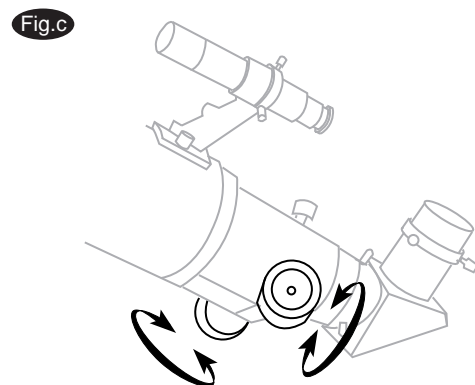

Using the Camera Adapter Tube

When you connect a camera directly to your telescope for "prime focus" photography, you sometimes require an adapter so that the camera can be focussed. Some refractors are designed to be used with diagonals so when used with only a camera, their focal length has to be extended. This is particularly true when photographing near objects. Your camera with its telescope "lens" may focus on a distant object such as a star, but will require the 2.5" camera adapter tube to focus on a near object such as a bird.

The camera adapter tube is easily installed by screwing it onto the T-threads of the eyepiece holder, then screwing the specific T-adapter ring for your camera (optional) onto the T-threads on the other end of the camera adapter tube. This makes the telescope into a "lens" which you then attach to your camera as you would any other lens.

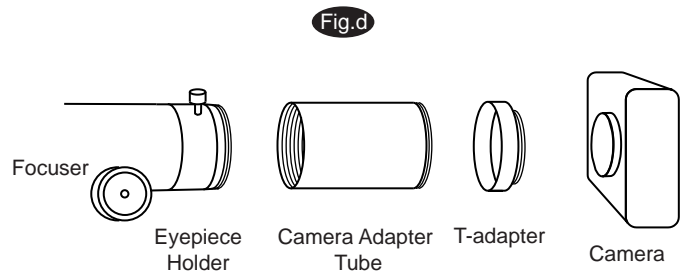

Pointing your telescope

Pointing an altitude-azimuth (alt-az) mounted telescope is relatively easy. With the mount level, you can swivel the telescope around on a plane parallel to your horizon and then tilt it up and down from there (Fig.c). You can think of it as turning your telescope in azimuth until it is facing the horizon below a celestial object and then tilting it up to the object's altitude. However, the Earth rotates and therefore the stars are constantly moving, so to track with this mount you need to constantly nudge the optical tube in both azimuth and altitude to keep the object in the field.

In reference material for your local position, the altitude will be listed as \pm degrees (minutes, seconds) above or below your horizon. Azimuth may be listed by the cardinal compass points such as N, SW, ENE, etc., but it is usually listed in 360 degree (minutes, seconds) steps clockwise from North (0°), with East, South and West being 90° , 180° and 270° , respectively (Fig.e).

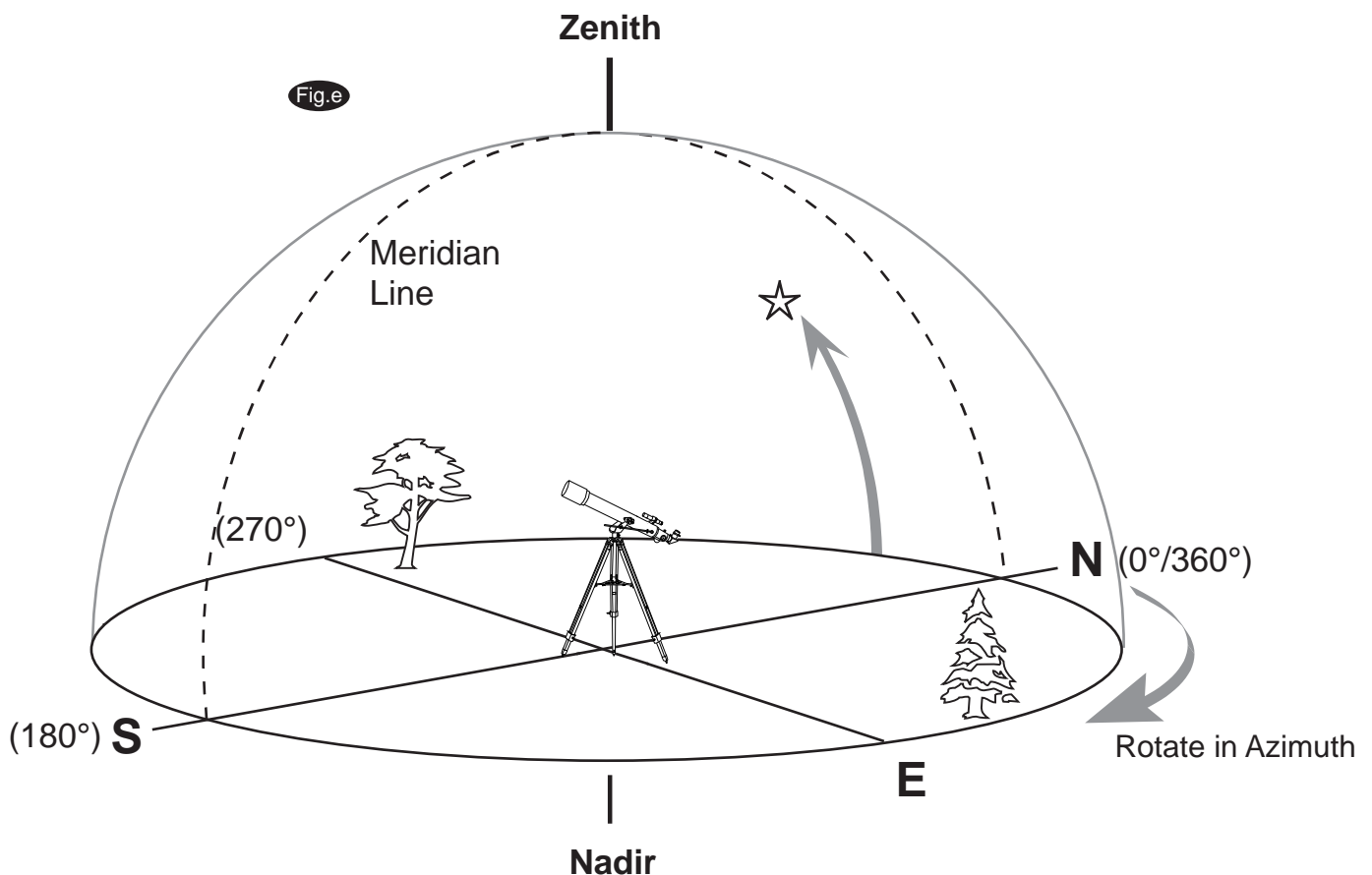

Calculating the magnification (power)

The magnification produced by a telescope is determined by the focal length of the eyepiece that is used with it. To determine a magnification for your telescope, divide its focal length by the focal length of the eyepieces you are going to use. For example, a 10mm focal length eyepiece will give 80X magnification with an 800mm focal length telescope.

$$\text{magnification} = \frac{\text{Focal length of the telescope}}{\text{Focal length of the eyepiece}} = \frac{800\text{mm}}{10\text{mm}} = 80\text{X}$$

When you are looking at astronomical objects, you are looking through a column of air that reaches to the edge of space and that column seldom stays still. Similarly, when viewing over land you are often looking through heat waves radiating from the ground, house, buildings, etc. Your telescope may be able to give very high magnification but what you end up magnifying is all the turbulence between the telescope and the subject. A good rule of thumb is that the usable magnification of a telescope is about 2X per mm of aperture under good conditions.

Calculating the field of view

The size of the view that you see through your telescope is called the true (or actual) field of view and it is determined by the design of the eyepiece. Every eyepiece has a value, called the apparent field of view, which is supplied by the manufacturer. Field of view is usually measured in degrees and/or arc-minutes (there are 60 arc-minutes in a degree). The true field of view produced by your telescope is calculated by dividing the eyepiece's apparent field of view by the magnification that you previously calculated for the combination. Using the figures in the previous magnification example, if your 10mm eyepiece has an apparent field of view of 52 degrees, then the true field of view is 0.65 degrees or 39 arc-minutes.

$$\text{True Field of View} = \frac{\text{Apparent Field of View}}{\text{Magnification}}$$

To put this in perspective, the moon is about 0.5° or 30 arc-minutes in diameter, so this combination would be fine for viewing the whole moon with a little room to spare. Remember, too much magnification and too small a field of view can make it very hard to find things. It is usually best to start at a lower magnification with its wider field and then increase the magnification when you have found what you are looking for. First find the moon then look at the shadows in the craters!

Calculating the exit pupil

The Exit Pupil is the diameter (in mm) of the narrowest point of the cone of light leaving your telescope. Knowing this value for a telescope-eyepiece combination tells you whether your eye is receiving all of the light that your primary lens or mirror is providing. The average person has a fully dilated pupil diameter of about 7mm. This value varies a bit from person to person, is less until your eyes become fully dark adapted and decreases as you get older. To determine an exit pupil, you divide the diameter of the primary of your telescope (in mm) by the magnification.

$$\text{Exit Pupil} = \frac{\text{Diameter of Primary mirror in mm}}{\text{Magnification}}$$

For example, a 200mm f/5 telescope with a 40mm eyepiece produces a magnification of 25x and an exit pupil of 8mm. This combination can probably be used by a young person but would not be of much value to a senior citizen. The same telescope used with a 32mm eyepiece gives a magnification of about 31x and an exit pupil of 6.4mm which should be fine for most dark adapted eyes. In contrast, a 200mm f/10 telescope with the 40mm eyepiece gives a magnification of 50x and an exit pupil of 4mm, which is fine for everyone.

OBSERVING THE SKY

Sky conditions

Sky conditions are usually defined by two atmospheric characteristics, seeing, or the steadiness of the air, and transparency, light scattering due to the amount of water vapour and particulate material in the air. When you observe the Moon and the planets, and they appear as though water is running over them, you probably have bad "seeing" because you are observing through turbulent air. In conditions of good "seeing", the stars appear steady, without twinkling, when you look at them with unassisted eyes (without a telescope). Ideal "transparency" is when the sky is inky black and the air is unpolluted.

Selecting an observing site

Travel to the best site that is reasonably accessible. It should be away from city lights, and upwind from any source of air pollution. Always choose as high an elevation as possible; this will get you above some of the lights and pollution and will ensure that you aren't in any ground fog. Sometimes low fog banks help to block light pollution if you get above them. Try to have a dark, unobstructed view of the horizon, especially the southern horizon if you are in the Northern Hemisphere and vice versa. However, remember that the darkest sky is usually at the "Zenith", directly above your head. It is the shortest path through the atmosphere. Do not try to observe any object when the light path passes near any protrusion on the ground. Even extremely light winds can cause major air turbulence as they flow over the top of a building or wall. If you try to observe on any structure, or even a sidewalk, movements you make may cause the telescope to vibrate. Pavement and concrete can also radiate stored heat which will affect observing.

Observing through a window is not recommended because the window glass will distort images considerably. And an open window can be even worse, because warmer indoor air will escape out the window, causing turbulence which also affects images. Astronomy is an outdoor activity.

Choosing the best time to observe

The best conditions will have still air, and obviously, a clear view of the sky. It is not necessary that the sky be cloud-free. Often broken cloud conditions provide excellent seeing. Do not view immediately after sunset. After the sun goes down, the Earth is still cooling, causing air turbulence. As the night goes on, not only will seeing improve, but air pollution and ground lights will often diminish. Some of the best observing time is often in the early morning hours. Objects are best observed as they cross the meridian, which is an imaginary line that runs through the Zenith, due North-South. This is the point at which objects reach their highest points in the sky. Observing at this time reduces bad atmospheric effects. When observing near the horizon, you look through lots of atmosphere, complete with turbulence, dust particles and increased light pollution.

Cooling the telescope

Telescopes require at least 10 to 30 minutes to cool down to outside air temperature. However this may take longer if there is a big difference between the temperature of the telescope and the outside air. This minimizes heat wave distortion inside telescope tube (tube currents). Allow a longer cooling time for larger optics. If you are using an equatorial mount, use this time for polar alignment.

Using your eyes

Do not expose your eye to anything except red light for 30 minutes prior to observing. This allows your pupils to expand to their maximum diameter and biochemical light adaptation to occur. It is important to observe with both eyes open. This avoids fatigue at the eyepiece, allows you to check against reference material, and is a good habit to develop if you sketch at the eyepiece. If you find this too distracting, cover the non-used eye with your hand or an eyepatch. Use averted vision on faint objects: The center of your eye is the least sensitive to low light levels. When viewing a faint object, don't look directly at it. Instead, look slightly to the side, and the object will appear brighter.

SUGGESTED READING

Amateur Astronomy

Beginner's Guide to Amateur Astronomy:

An Owner's Manual for the Night Sky by David J. Eicher and, Michael Emmerich (Kalmbach Publishing Co., Books Division, Waukesha, WI, 1993).

NightWatch: A Practical Guide to Viewing the Universe by Terence Dickinson, (Firefly Books, Willowdale, ON, Canada, 3rd edition, 1999).

Star Ware: The Amateur Astronomer's Ultimate Guide to Choosing, Buying, and Using Telescopes and Accessories by Philip S. Harrington (John Wiley & Sons, New York, 1998).

The Backyard Astronomer's Guide by Terence Dickinson and Alan Dyer (Firefly Books Ltd., Willowdale, ON, Canada, revised edition, 1994).

The Beginner's Observing Guide: An Introduction to the Night Sky for the Novice Stargazer by Leo Enright, (The Royal Astronomical Society of Canada, Toronto, ON, Canada, 1999).

The Deep Sky: An Introduction by Philip S. Harrington (Sky Publishing Corporation, Cambridge, MA, Sky & Telescope Observer's Guides Series, ed. Leif J. Robinson, 1997).

The Universe from Your Backyard: A Guide to Deep Sky Objects by David J. Eicher (Kalmbach Publishing Co., Books Division, Waukesha, WI, 1988).

Turn Left at Orion: A Hundred Night Sky Objects to See in a Small Telescope--and how to Find Them by Guy J. Consolmagno and Dan M. Davis, (Cambridge University Press, New York, 3rd edition, 2000)

Astrophotography

A Manual Of Advanced Celestial Photography by Brad D. Wallis and Robert W. Provin (Cambridge University Press; New York; 1984)

Astrophotography An Introduction by H.J.P. Arnold (Sky Publishing Corp., Cambridge, MA, Sky & Telescope Observer's Guides Series, ed. Leif J. Robinson, 1995).

Astrophotography for the Amateur: by Michael Covington (Cambridge University Press, Cambridge, UK, 2nd edition, 1999).

Splendors of the Universe: A Practical Guide to Photographing the Night Sky by Terence Dickinson and Jack Newton (Firefly Books, Willowdale, ON, Canada, 1997)

Wide-Field Astrophotography by Robert Reeves (Willmann-Bell, Inc., Richmond, VA, 2000).

Observational References

A Field Guide to the Stars and Planets by Jay M. Pasachoff, (Houghton Mifflin Company, 1999).

Atlas of the Moon by Antonín Růkl (Kalmbach Publishing Co., Books Division, Waukesha, WI, 1993).

Burnham's Celestial Handbook: An Observer's Guide to the Universe Beyond the Solar System by Robert Burnham (Dover Publications, New York; 3- volume set, 1978).

Observer's Handbook by The Royal Astronomical Society of Canada, (University of Toronto Press, Toronto, ON, Canada, published annually).

Sky Atlas 2000.0 by Wil Tirion and Roger W. Sinnott (Sky Publishing Corp., Cambridge, MA, 2nd edition, 1998)

Magazines

Astronomy Magazine (Kalmbach Publishing Co., Waukesha, WI)

Sky & Telescope Magazine (Sky Publishing Corp., Cambridge, MA)

SkyNews Magazine: The Canadian Magazine of Astronomy & Stargazing (SkyNews Inc., Yarker, ON, Canada)

TECHNICAL SUPPORT

Canada: Tel: 604-270-2813 between 9:00AM and 3:00PM PST, Fax: 604-270-2330
Outside Canada: Please contact your dealer for technical support.

Web site: www.SkywatcherTelescope.com
Technical Support e-mail: support@skywatchertelescope.com